



# INFO SPEC

## DESCRIPTION

Pressure reducing and regulating valves, generally called pressure regulators, are designed to automatically reduce a high inlet pressure to a lower outlet pressure and maintain that lower pressure within relatively close limits. Many plumbing codes require pressure reducing valves to be installed whenever water pressure exceeds 70 to 85 psi. E Series pressure regulators are designed primarily for residential or commercial water regulation; however, within the design limitations of each valve, they can prove functional and reliable for other water and air applications.

## OPERATION

### INSTALLATION INSTRUCTIONS

All E Series pressure regulators are supplied with the requested delivery pressure w a d-justed at the factory. Pressure adjustment is accomplished by loosening the lock nut and turning the adjusting screw either clockwise to increase delivery pressure or counter-clockwise to reduce delivery pressure. In actual operation, turning the adjusting screw clockwise forces the pressure spring to act against the diaphragm assembly (or directly against the piston in the case of the Type E-56 regulators) and move the internal valve seat to the open position. When high inlet pressure is applied, it flows into the regulator, through the open seat, under the diaphragm or piston to the outlet. As the outlet pressure builds up under the diaphragm or piston to the adjusted psi setting, the downward adjusting spring pressure is overcome and the regulating valve closes or throttles to maintain the required delivery pressure.

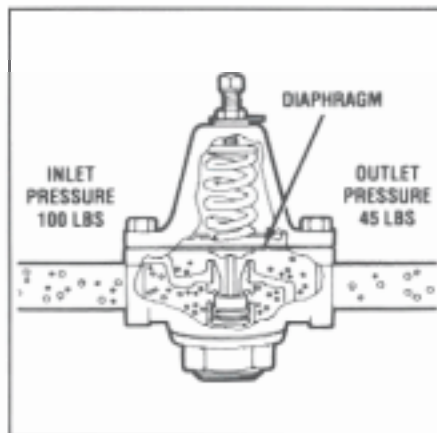

## PIPE SIZE CONSIDERATIONS

Water supply system pipe lines must be large enough to assure ample pressure and capacity at the highest fixture, on the topmost floor or in the most remote location. A flowing pressure of about 20 psi is generally considered the minimum for household service; industrial and commercial applications frequently require pressures to be higher.

A properly designed water supply system should provide the required capacity and pressure without allowing water velocity of more than 10 feet per second. A mistaken attempt at economy, however, often results in the installation of undersized piping which cannot provide adequate capacity without excessive water velocity. When water velocity exceeds 10 feet per second, highly undesirable pipe noises such as "singing," "humming," or "water hammer" may result. A pressure reducing and regulating valve is designed to reduce high water pressure, but it can only work effectively if the system is not properly designed. Pipe lines, therefore, should always be sized to provide adequate flow with reasonable water velocities and pressure losses.

# GENERAL REGULATOR INFORMATION & INSTALLATION INSTRUCTIONS

This Bulletin No.	IS-PRV3
Date Of This Issue	MAY 2000
Supersedes Bulletin No.	IS-PRV3
Dated	JULY 1999

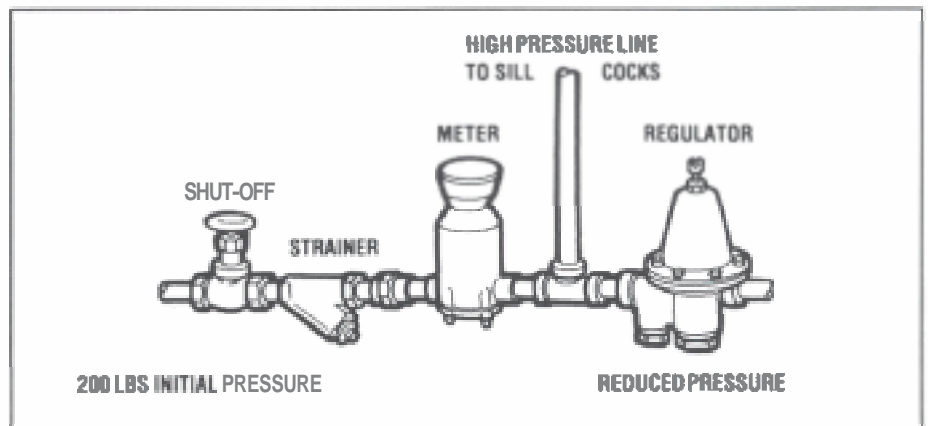

## GENERAL INSTALLATION INFORMATION

A water pressure regulator will normally give years of satisfactory service when correctly installed. The piping should first be thoroughly flushed out to assure removal of all foreign matter. Improperly cleaned pipelines are a common source of regulator damage and seat leakage. The pipe should be anchored firmly at the valve, and the valve must be installed with its inlet and outlet in proper relation with the rest of

the system. It is highly recommended that a separate strainer be installed in the pipeline ahead of every regulator that does not have an inbuilt strainer.

For ease of maintenance and repair, it is suggested that a shut-off valve be installed ahead of the regulator. In commercial installations, a second shut-off valve following the regulator with either a pressure gauge or tapping between the regulator and the downstream shut-off valve being recommended.

# GENERAL INFORMATION ON CASH-ACME PRESSURE REGULATORS ,

All E Series regulators are furnished with the reduced pressure setting clearly marked on a tag attached to the valve. The range of adjustment is also marked on the tag: the factory setting may be easily changed to any pressure within that range.

## MULTIPLE REGULATOR INSTALLATIONS

In systems where the inlet pressure exceeds 200 psi, there are certain advantages in carrying out the reduction in two stages. The first regulator reduces the pressure to approximately 100 psi: the second to 45 psi. Excessive wear on the inner working parts of each valve is avoided by such an arrangement.

For installations in hospitals, schools and commercial buildings, it is frequently advisable to install two regulators connected in parallel. This arrangement permits a smaller regulator to operate when demand is low (as for a drinking fountain in a large system): the larger regulator operates during periods of peak demand and provides the higher capacity necessary in such situations. Parallel installations also result in quieter operation since the larger valve is not required to handle low flows. In addition, the larger valve can be expected to offer longer life expectancy and require less maintenance.

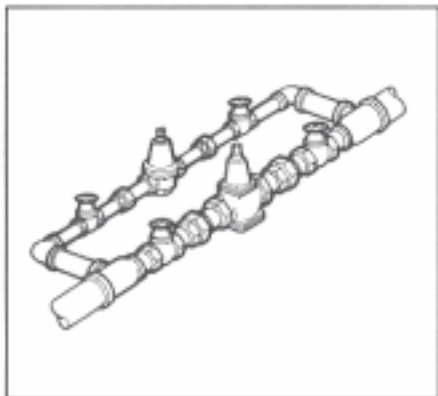

For a parallel installation to be effective, the smaller valve should be sized to handle approximately 10 to 20 percent of the system capacity with the larger regulator to handle the balance. In this arrangement, the smaller valve should be set for a pressure of approximately five psi higher than the larger valve. The larger valve will then begin operating when the smaller valve reaches full capacity and the outlet pressure begins to fall off.

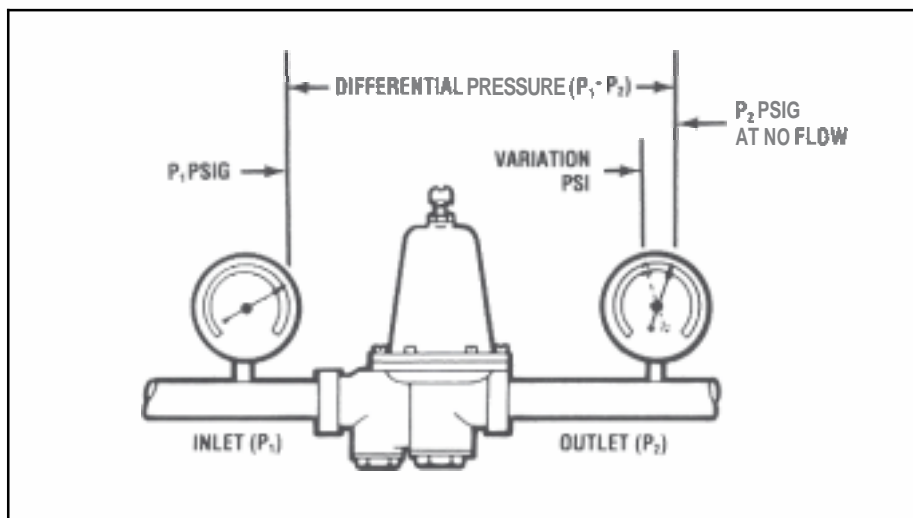

## CONTROLLING THERMAL EXPANSION

It is important to note that a pressure regulator tends to create a "closed" system, that is, water cannot normally flow back through the regulator. In a closed system, water pressure may rise due to thermal expansion - the phenomenon by which water increases in volume when heated, as in hot water heaters or boilers. Relief valves installed on these hot water heating devices are designed to open when system pressure reaches a pre-determined point, allowing water to escape until the pressure returns to a safe level.

To eliminate nuisance problems of pressure relief due to thermal expansion, Cash-Acme offers an inbuilt back-pass check valve in several regulators. When the pressure on the outlet (downstream) side of the regulator becomes greater than the inlet (upstream) pressure, the back-pass check allows the excess downstream pressure to bleed to the upstream side of the regulator until the pressure becomes equal. But because it can only allow water to flow back through the regulator when the system pressure is higher than the inlet pressure, a back-pass check valve is not effective when the pressure setting of the relief valve is equal to or lower than the inlet pressure.

The inbuilt back-pass check valve is not designed to replace an approved, properly sized and rated pressure and temperature relief valve. A relief valve should be installed in every system where a hot water heating device is installed.

## CAPACITY INFORMATION

For a given type and size, the amount of water a regulator will pass is governed by the difference between the inlet pressure ( $P_1$ ) and the outlet pressure ( $P_2$ ) of the valve. As this pressure differential increases, the volume of water increases. Inherent in all regulators of this type is a characteristic which causes the outlet pressure ( $P_2$ ) to drop off slightly as flow starts through the valve and to drop off even more as increased demand requires increased flow. The maximum capacity of a direct-acting regulator, then, is determined both by the differential between the inlet pressure ( $P_1$ ) and the outlet pressure ( $P_2$ ) and by how accurately the outlet pressure ( $P_2$ ) is to be maintained.

As pointed out above, reduced pressures must drop off slightly from the setting of the valve as flow increases, the pressure must continue to fall. The amount of flow (capacity) is then entirely dependent on where and how the valve is to be used. In the average water supply system where water is piped to lavatories, toilets, bath tubs, and showers in homes, schools, apartments, and hospitals, a pressure drop-off of 20 to 25 percent is considered satisfactory. In industrial or commercial applications such as laundries, car washers and commercial dishwashers, it may be desirable to hold the reduced pressure closer to the setting and permit only a 10 to 15 percent drop-off.

## CAPACITY TABLES

Capacity tables for each E Series regulator are provided in Bulletin PRV-E which may be requested by writing the factory. The tables provide the information necessary to correctly determine what size regulator is required for a particular application. The charts present capacities for each valve type and size while reflecting the effects of the two variables:  $P_2$  variation and pressure differential. The charts clearly show that both the  $P_2$  variation and pressure differential affect valve capacity: the greater the  $P_2$  variation, the higher the valve capacity; the greater the pressure differential, the higher the

capacity. Both variables must be given consideration when determining which regulator is required for a given application.

In any given situation with a fixed set of conditions, a larger valve will offer more capacity with less pressure fall off than a smaller valve of the same type. Further, you will notice that capacities for a particular pipe size will vary among valve types. E Series valves are engineered to a variety of performance criteria, so choosing a valve is determined by more than pipe size alone. If you require additional information, Cash-Acme's engineering department is ready at all times to assist you in your valve selection requirements.

## REPAIR PARTS INFORMATION

Repair parts are available for all Cash-Acme pressure reducing and regulating valves. For convenience in ordering, handy pre-packaged Repair Kits are available for Type E regulators. Each repair kit contains a diaphragm, seat disc and screw, bottom plug gasket, body seat, and pressure spring for 45 psi setting. In addition, a strainer screen and clean-out gasket are included for all but Type E-41 Series 3.

In lieu of a Repair Kit, individual parts may be ordered for all E Series regulators, including Types E-55 and E-56. Write Cash-Acme and request repair parts Information for the specific type regulator involved.



**IMI CASH VALVE INC.**  
2400 7TH AVENUE SW • CULLMAN, ALABAMA 35055  
1-800-879-2042 • FAX 1-800-879-2057  
256-775-8200 • FAX 256-775-8238  
[www.cashacme.com](http://www.cashacme.com)



© 2000 IMI CASH VALVE INC.